

## Changes in Arterial Pressure during Mechanical Ventilation

Frédéric Michard, M.D., Ph.D.\*

**CME** This article has been selected for the *Anesthesiology* CME Program. After reading the article, go to <http://www.asahq.org/journal-cme> to take the test and apply for Category 1 credit. Complete instructions may be found in the CME section at the back of this issue.

**Mechanical ventilation induces cyclic changes in vena cava blood flow, pulmonary artery blood flow, and aortic blood flow. At the bedside, respiratory changes in aortic blood flow are reflected by “swings” in blood pressure whose magnitude is highly dependent on volume status. During the past few years, many studies have demonstrated that arterial pressure variation is neither an indicator of blood volume nor a marker of cardiac preload but a predictor of fluid responsiveness. That is, these studies have demonstrated the value of this physical sign in answering one of the most common clinical questions, Can we use fluid to improve hemodynamics?, while static indicators of cardiac preload (cardiac filling pressures but also cardiac dimensions) are frequently unable to correctly answer this crucial question. The reliable analysis of respiratory changes in arterial pressure is possible in most patients undergoing surgery and in critically ill patients who are sedated and mechanically ventilated with conventional tidal volumes.**

IN a normal individual who is breathing spontaneously, blood pressure decreases on inspiration, but the peak decrease of systolic pressure does not exceed 5 mmHg. The exaggeration of this phenomenon, called *pulsus paradoxus*, was initially reported by Adolf Kussmaul in constrictive pericarditis and was described as a “pulse disappearing during inspiration and returning during expiration” despite the continued presence of the cardiac activity during both respiratory phases.<sup>1</sup>

A phenomenon that is the reverse of the conventional *pulsus paradoxus* has been reported during positive-pressure ventilation (fig. 1). The inspiratory increase in arterial blood pressure followed by a decrease on expiration has been called at different times *reversed pulsus*

*paradoxus*,<sup>2</sup> *paradoxical pulsus paradoxus*,<sup>3</sup> *respirator paradox*,<sup>4</sup> *systolic pressure variation* (SPV),<sup>5</sup> and *pulse pressure variation*.<sup>6</sup> In 1978, Rick and Burke<sup>4</sup> were the first to suggest a link between the volume status of critically ill patients and the SPV. From 1987, Perel’s group<sup>5,7-11</sup> conducted several animals studies clarifying the physiologic determinants of the SPV, and emphasizing the major role of volume status on its magnitude.

The clinical use of this physical sign has remained marginal. A 1998, German survey<sup>12</sup> suggested that only 1% of physicians consider the “swings” in blood pressure during respiration as part of their decision-making process regarding volume expansion.

The past few years have been marked by a controversy concerning the benefit/risk ratio of pulmonary artery catheterization.<sup>13-16</sup> Moreover, several publications<sup>17-19</sup> have emphasized the lack of value of cardiac filling pressures in answering one of the most common clinical question: Can we improve cardiac output and hence hemodynamics by giving fluid?. Interestingly, during the same period, at least 12 peer-reviewed English-language studies<sup>6,20-30</sup> have demonstrated the usefulness of the respiratory variation in arterial pressure (or its surrogates) in answering this crucial clinical question.

### *Physiologic Determinants of Respiratory Changes in Arterial Pressure*

**Respiratory Changes in Left Ventricular Stroke Volume** Morgan *et al.*<sup>31</sup> first reported that mechanical ventilation induces cyclic changes in vena cava blood flow, pulmonary artery blood flow, and aortic blood flow. During the inspiratory period, the vena cava blood flow decreases first, followed by a decrease in pulmonary artery flow and then in aortic blood flow (fig. 2). The decrease in vena cava blood flow, *i.e.*, in venous return, has been related both to an increase in right atrial pressure<sup>32,33</sup> (the downstream pressure of venous return) and to the compression of the vena cava due to the inspiratory increase in pleural pressure during mechanical ventilation.<sup>30,34-36</sup> According to the Frank-Starling mechanism,<sup>37</sup> the inspiratory decrease in right ventricular preload results in a decrease in right ventricular

\* Clinical Research Fellow, Anesthesia and Critical Care, Massachusetts General Hospital—Harvard Medical School, Boston, Massachusetts. Médecin Spécialiste, Ancien Chef de Clinique, Critical Care, Marie Lannelongue Hospital, University Paris XI, Paris, France.

Received from the Department of Anesthesia and Critical Care, Massachusetts General Hospital—Harvard Medical School, Boston, Massachusetts. Submitted for publication May 11, 2004. Accepted for publication December 16, 2004. Support was provided solely from institutional and/or departmental sources.

Address reprint requests to Dr. Michard: [michard.frederic@free.fr](mailto:michard.frederic@free.fr).

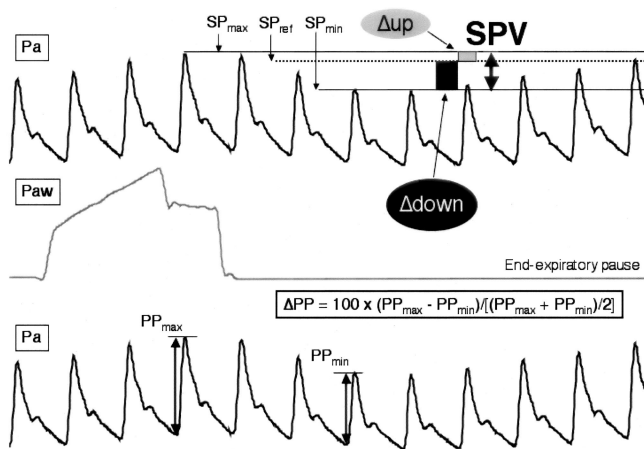

**Fig. 1.** Analytical description of respiratory changes in arterial pressure during mechanical ventilation. The systolic pressure and the pulse pressure (systolic minus diastolic pressure) are maximum (SP<sub>max</sub> and PP<sub>max</sub>, respectively) during inspiration and minimum (SP<sub>min</sub> and PP<sub>min</sub>, respectively) a few heartbeats later, *i.e.*, during the expiratory period. The systolic pressure variation (SPV) is the difference between SP<sub>max</sub> and SP<sub>min</sub>. The assessment of a reference systolic pressure (SP<sub>ref</sub>) during an end-expiratory pause allows the discrimination between the inspiratory increase ( $\Delta_{up}$ ) and the expiratory decrease ( $\Delta_{down}$ ) in systolic pressure. Pa = arterial pressure; Paw = airway pressure.

output and pulmonary artery blood flow that finally leads to a decrease in left ventricular filling and output.

Three other mechanisms may also participate in the respiratory variation in left ventricular stroke volume (figs. 3 and 4): (1) Right ventricular afterload increases during inspiration because the increase in alveolar pressure (the pressure surrounding the pulmonary capillaries) is greater than the increase in pleural pressure (the pressure surrounding the pulmonary arterial bed). In this regard, any increase in transpulmonary pressure (the difference between alveolar and pleural pressure) impedes right ventricular ejection.<sup>38-40</sup> (2) Left ventricular preload increases during inspiration because the increase in alveolar pressure (surrounding the pulmonary capillaries) is greater than the increase in pleural pressure (surrounding the pulmonary venous bed). Thus, the

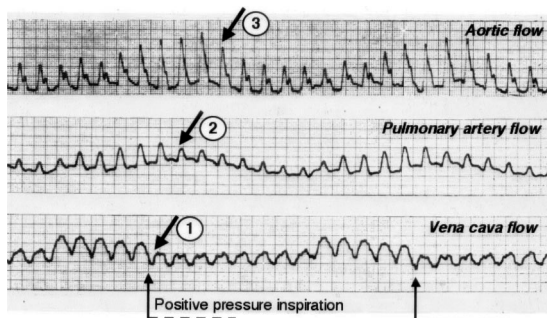

**Fig. 2.** Phasic flow tracings of vena cava blood flow, pulmonary artery blood flow, and aortic blood flow. Positive-pressure inspiration induces successively a decrease in vena cava blood flow (1), a decrease in pulmonary artery blood flow (2), and a decrease in aortic blood flow (3). From Morgan *et al.*<sup>31</sup>; used with permission.

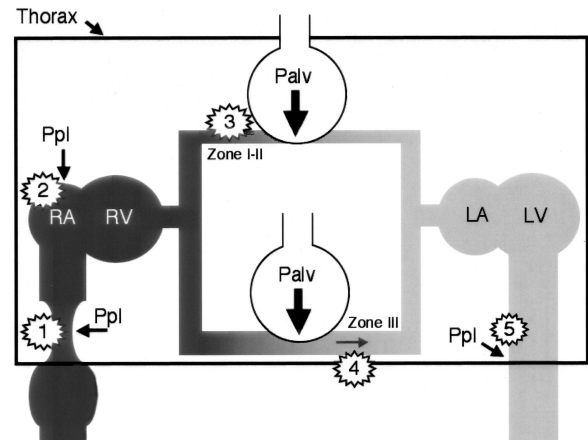

**Fig. 3.** Physiologic effects of mechanical ventilation in hypovolemic conditions. Right ventricular preload decreases because the increase in pleural pressure induces a compression of the superior vena cava (1) and an increase in intramural right atrial pressure (2), while the transmural right atrial pressure decreases. In West zones I (pulmonary arterial pressure < alveolar pressure) and II (pulmonary venous pressure < alveolar pressure), right ventricular afterload increases because pulmonary capillaries are compressed (3). In West zones III (alveolar pressure < pulmonary venous pressure), the increase in alveolar pressure squeezes out the blood contained in the capillaries toward the left side of the heart (4). The increase in pleural pressure induces a decrease in left ventricular afterload (5). LA = left atrium; LV = left ventricle; Palv = alveolar pressure; Ppl = pleural pressure; RA = right atrium; RV = right ventricle.

blood is squeezed out of the capillaries toward the left side of the heart.<sup>41,42</sup> (3) Left ventricular afterload decreases during inspiration because positive pleural pressure increases the systolic extracardiac pressure and decreases the systolic intracardiac pressure through a reduction in thoracic blood volume.<sup>43-45</sup>

In summary, the left ventricular stroke volume in-

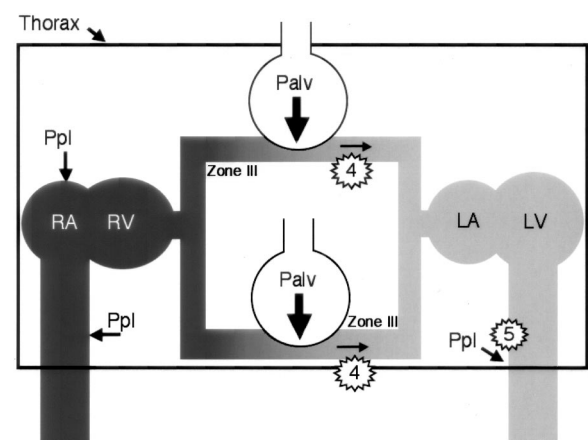

**Fig. 4.** Physiologic effects of mechanical ventilation in hypervolemic conditions. The vena cava and right atrium are poorly compliant and compressible and hence relatively insensitive to changes in pleural pressure. West zones III (alveolar pressure < pulmonary venous pressure) are predominant in the lungs such that each mechanical breath increases pulmonary venous flow and left ventricular preload (4). The increase in pleural pressure induces a decrease in left ventricular afterload (5). LA = left atrium; LV = left ventricle; Palv = alveolar pressure; Ppl = pleural pressure; RA = right atrium; RV = right ventricle.

creases during inspiration because left ventricular preload increases while left ventricular afterload decreases. In contrast, the right ventricular stroke volume decreases during inspiration because right ventricular preload decreases while right ventricular afterload increases. Because of the long (approximately 2 s) pulmonary transit time of blood,<sup>46</sup> the inspiratory decrease in right ventricular output causes a decrease in left ventricular filling and output only a few heartbeats later, *i.e.*, usually during the expiratory period (fig. 1).

**Respiratory Changes in Systolic and Pulse Pressures** The arterial pulse pressure (the difference between the systolic and the preceding diastolic pressure) is directly proportional to stroke volume and inversely related to arterial compliance.<sup>47</sup> Therefore, for a given arterial compliance, the amplitude of pulse pressure is directly related to left ventricular stroke volume. In this regard, the respiratory variation in left ventricular stroke volume has been shown to be the main determinant of the respiratory variation in pulse pressure.<sup>46</sup> The systolic pressure is less closely related to stroke volume than the pulse pressure because it depends not only on stroke volume<sup>48</sup> and arterial compliance but also directly on diastolic pressure (systolic pressure = diastolic pressure + pulse pressure). Therefore, the respiratory variation in systolic pressure depends not only on respiratory variations in left ventricular stroke volume but also directly on changes in extramural aortic pressure (*i.e.*, on changes in pleural pressure).<sup>49,50</sup> The systolic pressure may vary over a single mechanical breath, whereas the pulse pressure and the left ventricular stroke volume do not change significantly. This may explain why in some patients, changes in systolic pressure poorly reflect concomitant changes in left ventricular stroke volume.<sup>51</sup>

**Influence of Volume Status on Respiratory Changes in Systolic and Pulse Pressures** In hypovolemic conditions, the respiratory variations in stroke volume and arterial pressure are of greater magnitude for at least four reasons (fig. 3). First, the venous system, and particularly the superior vena cava submitted to the pleural pressure, is more collapsible in hypovolemic states. Accordingly, the respiratory variations in vena cava diameter produced by mechanical ventilation are reduced by volume loading.<sup>30,35,52</sup> Second, the inspiratory increase in right atrial pressure (the back-pressure to venous return) may be greater in hypovolemic conditions because of the higher transmission of pleural pressure inside the right atrium when the right atrium is underfilled and hence more compliant.<sup>53,54</sup> Third, West zone I (pulmonary arterial pressure < alveolar pressure) or II (pulmonary venous pressure < alveolar pressure) conditions<sup>55</sup> are more likely encountered in a hypovolemic state and hence the effect of inspiration on right ventricular afterload is also more marked in this context. Finally, the right and left ventricles are more sensitive to changes in preload when they operate on the steep (left)

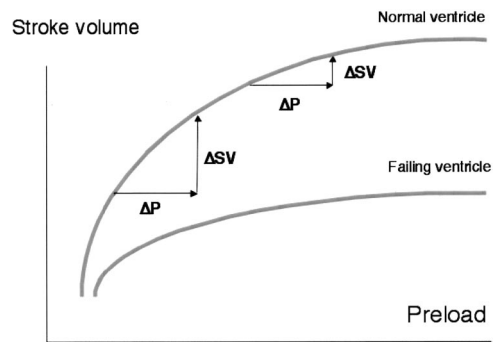

Fig. 5. Schematic representation of the Frank-Starling relation between ventricular preload (*x-axis*) and stroke volume (*y-axis*). The lower the ventricular preload, the more likely the ventricle is operating on the steep portion of the curve and hence a given change in preload ( $\Delta P$ ) will induce a significant change in stroke volume ( $\Delta SV$ ).

portion of the Frank-Starling curve<sup>37</sup> than on the flat (right) portion of the curve (fig. 5). The lower the ventricular preload is, the more likely the ventricles are operating on the steep portion of the curve.

Because the four mechanisms described above are responsible for a decrease in right ventricular output during inspiration, it has been clearly shown by many experimental and clinical studies<sup>5-7,9-11,20-22,25,28,56-59</sup> that in hypovolemic conditions, the magnitude of the respiratory variation in arterial pressure is *large*, and the main component of this variation is the *expiratory decrease* in left ventricular output that follows (after a few heartbeats) the inspiratory decrease in right ventricular output (fig. 3). In contrast, hypervolemia counteracts these four mechanisms and increases the amount of blood boosted from the pulmonary capillary bed toward the left side of the heart during each lung inflation (fig. 4).<sup>41</sup> Therefore, in hypervolemic conditions, the magnitude of the respiratory variation in arterial pressure is *low*, and the main component of this variation becomes the *inspiratory increase* in left ventricular output.<sup>8-10,56</sup>

#### Analytical Description of Respiratory Changes in Systolic and Pulse Pressures

The arterial pressure curve is usually displayed on bedside monitors, and the mere observation of the curve could be considered an adequate method to assess the respiratory variation in arterial pressure produced by mechanical ventilation. However, as illustrated in figure 6, the shape of the curve is highly variable according to the scale and the speed of the arterial tracing, emphasizing the need for methods allowing the quantification of this phenomenon.

The first method that has been proposed to analyze and quantify the respiratory variation in blood pressure produced by mechanical ventilation is the calculation of the difference between the maximum and the minimum systolic pressure over a single respiratory cycle, the SPV (fig. 1).<sup>4</sup> To discriminate between what is happening



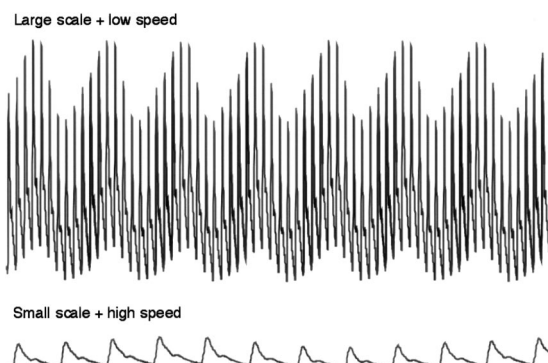

Fig. 6. The same arterial pressure recorded at different scale and speed. The arterial pressure waveform varies with recording scale and speed, emphasizing the need for a quantification of respiratory changes in arterial pressure.

during inspiration and during expiration, Perel *et al.*<sup>5</sup> proposed to divide the SPV into two components ( $\Delta_{up}$  and  $\Delta_{down}$ ). These two components are calculated using a reference systolic pressure, which is the systolic pressure measured during a short apnea or end-expiratory pause of 5–30 s.<sup>5,58</sup> Other authors have proposed to consider the systolic pressure just before the onset of inspiration<sup>56</sup> or during a brief disconnection from the ventilator.<sup>42</sup> The  $\Delta_{up}$  is calculated as the difference between the maximal value of systolic pressure over a single respiratory cycle and the reference systolic pressure (fig. 1). The  $\Delta_{up}$  reflects the inspiratory increase in systolic pressure, which may result from an increase in left ventricular stroke volume (*i.e.*, increase in pulse pressure), an increase in extramural aortic pressure (*i.e.*, increase in diastolic pressure), or both. The  $\Delta_{down}$  is calculated as the difference between the reference systolic pressure and the minimal value of systolic pressure over a single respiratory cycle (fig. 1). The  $\Delta_{down}$  reflects the expiratory decrease in left ventricular stroke volume related to the inspiratory decrease in right ventricular stroke volume.

To more accurately track changes in left ventricular stroke volume, Michard *et al.*<sup>6</sup> proposed to quantify the respiratory variation in arterial pulse pressure ( $\Delta PP$ ) by calculating the difference between the maximum and minimum pulse pressures (PPmax and PPmin, respectively) over a single mechanical breath, normalized by the mean of the two values and expressed as a percentage (fig. 1):  $\Delta PP (\%) = 100 \times (PP_{max} - PP_{min}) / [(PP_{max} + PP_{min}) / 2]$ .

More recently, it has also been proposed to quantify the expiratory decrease in arterial pulse pressure, using the pulse pressure measured during an end-expiratory pause as the reference pulse pressure.<sup>60</sup> In 17 mechanically ventilated patients, the expiratory component of  $\Delta PP$  was found to be interchangeable with  $\Delta PP$ , emphasizing the minimal role of the inspiratory increase in left ventricular stroke volume in the respiratory variation in stroke volume.

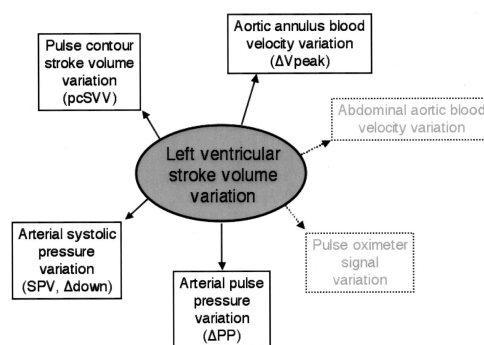

Fig. 7. Techniques available at the bedside to assess the respiratory variation in left ventricular stroke volume induced by mechanical ventilation. The abdominal aortic blood velocity variation and the pulse oximeter signal variation have not been validated to predict fluid responsiveness.

Other techniques have been proposed to assess the respiratory variation in left ventricular stroke volume (fig. 7). The pulse contour analysis, based on the computation of the area under the systolic portion of the arterial pressure curve according to a modified Wesseling algorithm, allows a beat-to-beat measurement of left ventricular stroke volume and hence the quantification of its variation over a short period of a few seconds.<sup>24–27,29</sup> If this time frame includes at least one respiratory cycle and does not exceed a few seconds, the calculated stroke volume variation reflects quite fairly the respiratory variation in stroke volume, the main determinant of the blood pressure variation over a time period less than 10 s.<sup>61</sup> The Doppler recording of aortic blood flow has been used to quantify the respiratory variation in aortic peak velocity or in velocity time integral at the level of the aortic annulus or in the descending aorta.<sup>23,62–65</sup> The pulse oximeter plethysmographic waveforms have been compared to the arterial pressure variation, but despite significant relations between the two phenomena, discrepancies have been reported, supporting the notion that pulse oximetry cannot be recommended to accurately assess the respiratory variation in arterial pressure in mechanically ventilated patients.<sup>66–68</sup>

#### Clinical Usefulness

##### Assessment of Volume Status and Cardiac Preload

Rick and Burke<sup>4</sup> were the first to establish a link between the magnitude of the arterial pressure variation and blood volume status of critically ill patients. In a study published in 1978 in which more than 100 mechanically ventilated patients were enrolled, they observed that SPV is frequently greater than 10 mmHg in the case of hypovolemia (that was defined according to clinical, radiologic, and pulmonary artery catheter criteria) and, in contrast, that SPV is usually lower than 10 mmHg in normovolemic and hypervolemic conditions (fig. 8).

Several clinical studies have shown that increasing blood volume decreases the respiratory variation in ar-

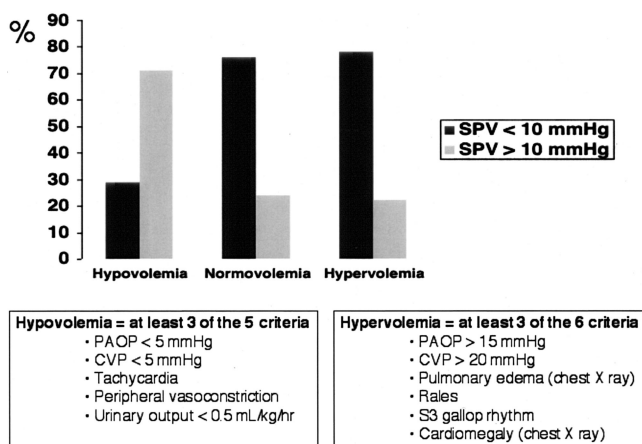

**Fig. 8.** Systolic pressure variation (SPV) in hypovolemic, normovolemic, and hypervolemic patients. The *y*-axis represents the percentage of patients who had an SPV less than 10 mmHg (black bar) or greater than 10 mmHg (gray bar). This is the first study showing a link between SPV and the volemic status of critically ill patients. SPV is frequently greater than 10 mmHg in hypovolemic patients but remains below this threshold value in almost 30% of cases. CVP = central venous pressure; PAOP = pulmonary artery occlusion pressure. Adapted from Rick and Burke<sup>4</sup>; used with permission.

arterial pressure and, conversely, that volume depletion increases this phenomenon.<sup>6,20-22,56</sup> However, it must be noted that a parameter can be very sensitive to changes in volume status without being necessarily a good indicator of circulating blood volume, because this parameter may be influenced by many other factors. For example, a decrease in blood volume usually produces a decrease in central venous pressure and *vice versa*. However, a given central venous pressure is a poor indicator of blood volume<sup>69</sup> because it depends not only on blood volume but also on venous compliance, pleural pressure, and abdominal pressure.

The SPV has been shown to correlate significantly with the pulmonary artery occlusion pressure such that the higher the SPV is, the lower the pulmonary artery occlusion pressure is.<sup>70,71</sup> The left ventricular end-diastolic area assessed by echocardiography is a better indicator of left ventricular preload than the pulmonary artery occlusion pressure<sup>72</sup> and a parameter very sensitive to changes in blood volume.<sup>73</sup> In the postoperative period of aortic vascular surgery, Coriat *et al.*<sup>20</sup> observed a significant relation between the left ventricular end-diastolic area and the magnitude of SPV, whereas in patients undergoing major surgery (mainly cardiac surgery), Dalibon *et al.*<sup>74</sup> did not detect a low left ventricular end-diastolic area by assessing SPV. More recently, Reuter *et al.*<sup>75</sup> reported significant but weak ( $r^2 = 0.34-0.38$ ) relations between the pulse pressure variation and another volumetric indicator of cardiac preload, the global end-diastolic volume evaluated by transpulmonary thermodilution.<sup>76</sup>

Other studies have shown that the magnitude of the respiratory variation in arterial pressure is affected by the

tidal volume,<sup>9,77</sup> the chest wall compliance,<sup>8,78</sup> or the level of positive end-expiratory pressure (PEEP),<sup>6,79</sup> whereas the total blood volume is not (at least on a short term basis). Therefore, if the arterial pressure variation depends on volume status, it also depends on other parameters such that the magnitude of the arterial pressure variation cannot be used to accurately assess total blood volume or cardiac preload.

However, in the decision-making process regarding volume expansion, the real clinical issue is not to know the total blood volume (the optimal blood volume in a patient vasodilated by sepsis or anesthetic agents is difficult to determine), but rather to know whether a fluid challenge will improve hemodynamics.<sup>80-83</sup>

**Prediction of Hemodynamic Response to Volume Expansion** The expected hemodynamic response to a fluid challenge is an increase in cardiac preload and, according to the Frank-Starling mechanism,<sup>37</sup> an increase in stroke volume and cardiac output. Predicting fluid responsiveness may be very useful in obviating the need for unnecessary fluid loading, and in detecting patients who may benefit from a volume load. During the past few years, many clinical studies have emphasized the value of the SPV, the pulse pressure variation, and the echo-Doppler or pulse contour stroke volume variation in predicting fluid responsiveness. These studies,<sup>6,20-30</sup> summarized in table 1, have also emphasized the lack of value of static indicators of cardiac preload (*e.g.*, central venous pressure, pulmonary artery occlusion pressure, left ventricular end-diastolic area) in identifying patients who may benefit from a volume load. As mentioned above and in figure 7, other techniques such as the Doppler recording of aortic blood velocity in the descending aorta or pulse oximetry have been proposed to assess respiratory changes in left ventricular stroke volume but until now have not been evaluated to predict fluid responsiveness in human beings.

**What Is the Best Predictor of Fluid Responsiveness?** Answering this question is quite difficult because the clinical studies mentioned above are not comparable in terms of patient population, fluid regimen, or criteria used to define a positive response to a fluid challenge (table 1). Few studies have compared the value of different parameters in the same population and with the same methodology. Tavernier *et al.*<sup>21</sup> compared SPV to  $\Delta$ down but did not demonstrate any statistically significant difference between the predictive value of the two parameters. Using receiver operating curve analysis, Michard *et al.*<sup>22</sup> demonstrated a slight but significant superiority of  $\Delta$ PP over SPV in identifying responders and nonresponders to a volume load. Their findings have recently been confirmed in postoperative cardiac surgery patients.<sup>28</sup> SPV,  $\Delta$ down, and  $\Delta$ PP were significantly correlated with the percent increase in stroke volume as a result of fluid infusion, but the best correlation was observed with  $\Delta$ PP (table 1). From a physiologic point of

**Table 1. Clinical Studies Investigating the Value of Arterial Pressure Variation (or Its Surrogates) in Predicting Fluid Responsiveness**

Study	Patients	Fluid	Volume	V <sub>T</sub> , ml/kg	Parameters Tested (Artery)	Regression Analysis	r <sup>2</sup>	Definition of Responders	Best Cutoff Value	Se.	Sp.	PPV	NPV
Coriat <i>et al.</i> <sup>20</sup>	Post aortic surgery	5% Alb.	500 ml	10–15	Δdown (R)	Δdown/ΔCO	0.34						
Tavernier <i>et al.</i> <sup>21</sup>	Sepsis	HES	500 ml	8–11	Δdown (R)	Δdown/ΔSV	0.58	ΔSV ≥ 15%	5 mmHg			95	93
Michard <i>et al.</i> <sup>6</sup>	ALI/sepsis	HES	500 ml	7–12	ΔPP (R or F)	ΔPP/ΔCO	0.94						
Michard <i>et al.</i> <sup>22</sup>	Sepsis	HES	500 ml	8–12	ΔPP (R or F) SPV	ΔPP/ΔCO SPV/ΔCO	0.85 0.69	ΔCO ≥ 15%	13%	94	96	94	96
Feissel <i>et al.</i> <sup>23</sup>	Sepsis	HES	8 ml/kg	8–10	ΔVpeak	ΔVpeak/ΔSV	0.83	ΔCO ≥ 15%	12%	100	89	91	100
Berkenstadt <i>et al.</i> <sup>24</sup>	Neurosurgery	HES	100 ml	10	pcSVV (F)	pcSVV/ΔSV	0.52	ΔSV > 5%	9.5%	79	93		
Reuter <i>et al.</i> <sup>25</sup>	Post cardiac surgery	Gelatin	20 × BMI		pcSVV (F)	pcSVV/ΔSV	0.45						
Reuter <i>et al.</i> <sup>26</sup>	Post cardiac surgery	Gelatin	20 × BMI	13–15	pcSVV (F)	pcSVV/ΔC	0.55						
Reuter <i>et al.</i> <sup>27</sup>	Post cardiac surgery	HES	10 × BMI	10	pcSVV (F)	pcSVV/ΔSV	0.55						
Bendjelid <i>et al.</i> <sup>28</sup>	Post cardiac surgery	9‰ NaCl	> 500 ml	5–10	ΔPP (R) SPV	ΔPP/ΔSV SPV/ΔSV	0.83 0.52						
Marx <i>et al.</i> <sup>29</sup>	Sepsis	HES	500 ml	6–8	pcSVV (F)	pcSVV/ΔC	0.41						
Vieillard-Baron <i>et al.</i> <sup>30</sup>	Sepsis	HES	10 ml/kg	8 ± 2	ΔPP (R)			ΔCO ≥ 11%	12%	90	87		

Alb. = albumin; ALI = acute lung injury; BMI = body mass index; ΔCO = volume loading–induced increase in cardiac output; Δdown = expiratory decrease in systolic pressure; F = femoral; HES = hydroxyethyl starch; NPV = negative predictive value; pcSVV = pulse contour stroke volume variation; ΔPP = pulse pressure variation; PPV = positive predictive value; R = radial; r<sup>2</sup> = correlation coefficient of the linear regression analysis presented in the previous column; Se. = sensitivity; Sp. = specificity; SPV = systolic pressure variation; ΔSV = volume loading–induced increase in stroke volume; V<sub>T</sub> = tidal volume.

view, it should be better to characterize respiratory variations in left ventricular stroke volume than surrogates such as SPV or ΔPP, but such a comparison has not yet been published. The analysis of the arterial blood pressure curve may remain the simplest way to predict fluid responsiveness because most patients with acute circulatory failure are instrumented with an arterial line, allowing the automatic calculation of the arterial pressure variation by bedside monitors in the near future.

**Prediction of Hemodynamic Response to Positive End-expiratory Pressure** In ventilated patients with acute lung injury, PEEP is frequently used for the alveolar recruitment of poorly aerated lung areas to improve arterial oxygenation. However, PEEP may decrease cardiac output and thus offset the expected benefits in terms of oxygen delivery. The adverse hemodynamic effects of PEEP are not easily predictable in clinical practice, although they were shown to be more likely to occur in patients with low left ventricular filling pressure.<sup>84</sup> The deleterious hemodynamic effects of PEEP are mediated by an increase in pleural pressure (reducing right ventricular filling) and an increase in transpulmonary pressure (increasing right ventricular afterload). As mentioned above, these are two major determinants of the respiratory variation in stroke volume and arterial pressure (fig. 3). In this regard, the hemodynamic effects of PEEP are reflected in the arterial pressure waveform: when cardiac output decreases with PEEP, the arterial pressure variation increases; if PEEP does not affect cardiac output, the arterial pressure variation is similarly unaffected by PEEP.<sup>6,79</sup> In the absence of cardiac output measurement during mechanical ventilation with PEEP, the analysis of the arterial pressure waveform may be

useful in assessing changes in cardiac output. Moreover, the magnitude of arterial pressure variation before the application of PEEP has been shown to be proportional to the decrease in cardiac output observed when PEEP is applied.<sup>6</sup> That is, the arterial pressure waveform analysis is also useful to predict, and hence to prevent, the deleterious hemodynamic effects of PEEP in mechanically ventilated patients.

#### Limitations

**Technical Factors** Because in clinical practice the arterial pressure curve is obtained from fluid filled catheters, several factors (air bubbles, kinks, clot formation, compliant tubing, excessive tubing length) may affect the dynamic response of the monitoring system.<sup>85</sup> The dynamic response of the monitoring system can be assessed by the fast-flush test, performed by briefly opening and closing the valve in the continuous flush device, producing a square wave displacement on the monitor followed by a return to baseline, usually after a few smaller oscillations. An optimal fast-flush test results in one undershoot followed by a small overshoot and then settles to the patient's waveform.<sup>85</sup> The site of arterial pressure monitoring can also impact the observed pressures, with significant differences between central (*e.g.*, femoral) and peripheral (*e.g.*, radial) systolic and pulse pressures. The pulse amplification from the aortic root to the peripheral circulation is a well-known phenomenon characterized in healthy subjects by a significant increase in systolic pressure associated with a slight decrease in diastolic pressure.<sup>86</sup> However, lower systolic pressures have been reported in peripheral arteries (as compared with central arteries) in septic patients<sup>87</sup> and



after cardiopulmonary bypass.<sup>88</sup> Both radial and femoral cannulations have been used to assess the respiratory variation in arterial pressure during mechanical ventilation (table 1). Whether the magnitude of the variation—expressed either as mmHg or as a percentage of variation—is the same at both sites remains to be determined.

**Atherosclerosis** As mentioned previously, systolic and pulse pressures depend not only on stroke volume but also directly on arterial compliance.<sup>47</sup> Therefore, for a given change in left ventricular stroke volume, SPV and  $\Delta$ PP may vary from one patient to another according to the arterial compliance. To this extent, large changes in arterial pressure may be observed despite small changes in left ventricular stroke volume if arterial compliance is low (e.g., elderly patients with peripheral vascular disease). Similarly, small changes in arterial pressure could be observed despite large changes in left ventricular stroke volume if arterial compliance is high (e.g., young patients without vascular disease).

**Cardiac Rhythm** Both heart rate and heart rate variability may affect the magnitude of the respiratory variation in arterial pressure: A decrease in heart rate<sup>59,89</sup> or an increase in heart rate variability<sup>62</sup> may decrease the respiratory variation in arterial pressure. It must be noted that the high value of the respiratory variation in arterial pressure as a predictor of fluid responsiveness has been demonstrated mainly in septic patients (table 1), *i.e.*, in patients who are usually tachycardic and characterized by decreased heart rate variability.<sup>90</sup>

In patients with cardiac arrhythmias, the beat-to-beat variation in stroke volume and hence in blood pressure may no longer reflect the effects of mechanical ventilation. This is particularly true in patients with atrial fibrillation or frequent extrasystoles. In patients with few extrasystoles, the arterial pressure curve can still be analyzed if the cardiac rhythm is regular during at least one respiratory cycle. However, significant cardiac ectopy rules out the continuous and automatic monitoring of this phenomenon.

**Small Variations in Pleural and Transpulmonary Pressures** If changes in pleural and transpulmonary pressure are small over a single respiratory cycle, inspiration does not induce any significant change in vena caval, pulmonary arterial and aortic flows, even during hypovolemic conditions. Small variations in pleural and transpulmonary pressures may be observed in patients with spontaneous breathing activity, in patients mechanically ventilated with small tidal volumes<sup>91</sup> (e.g., 6 ml/kg), or in patients with increased chest compliance. In this context, caution should be exercised before concluding that a patient will not respond to a fluid challenge because no variation in blood pressure is observed. It has been clearly shown that increasing tidal volume<sup>9,77</sup> or reducing chest compliance<sup>8,78</sup> causes increases in stroke volume and blood pressure variations. The possible influence of tidal volume and chest compliance on

the hemodynamic response to a volume load is less clear. By increasing the mean pleural pressure, any increase in tidal volume should impede the venous return, and hence induce a leftward shift on the Frank-Starling curve. Therefore, a patient operating on the flat part of the Frank-Starling curve (and insensitive to changes in preload, *i.e.*, to fluid administration) when ventilated with a small tidal volume may theoretically operate on the steep portion of the curve (leftward shift) and hence become fluid responsive when ventilated with a large tidal volume. In this regard, it has been suggested that the hemodynamic effects of volume expansion also depend on tidal volume, which should minimize the influence of tidal volume on the value of arterial pressure variation as a predictor of fluid responsiveness.<sup>92</sup> A similar reasoning could be applied to changes in chest wall compliance because it has recently been shown that opening the chest (sternotomy) not only decreases stroke volume variation but also increases cardiac preload and thus, by inducing a rightward shift on the Frank-Starling curve, probably decreases the sensitivity of the heart to a fluid challenge.<sup>75</sup>

Concerns have also been raised regarding the possible influence of lung compliance on the arterial pressure variation.<sup>93</sup> Lung compliance influences the transmission of alveolar pressure to the pleural space, and it has been shown that the percentage of transmission is roughly equal to static compliance of the respiratory system ( $C_{st,rs}$ ).<sup>94,95</sup> For a given tidal volume of 500 ml, an airway plateau pressure of 10 cm H<sub>2</sub>O, and no PEEP,  $C_{st,rs}$  can be calculated as  $500/10 = 50$  ml/cm H<sub>2</sub>O. Assuming that in this context the percentage of transmission of alveolar pressure to the pleural space is around 50%, changes in pleural pressure should approximate  $10 \times 50\% = 5$  cm H<sub>2</sub>O. If lung compliance is reduced such that  $C_{st,rs}$  is now 25 ml/cm H<sub>2</sub>O, the airway plateau pressure will go up to 20 cm H<sub>2</sub>O, the percentage of transmission will go down to 25%, and changes in pleural pressure should remain of the same magnitude:  $20 \times 25\% = 5$  cm H<sub>2</sub>O. Therefore, changes in lung compliance will not necessarily affect changes in pleural pressure. Only a decrease in tidal volume associated with a decrease in lung compliance (e.g., to limit the airway plateau pressure and the risk of ventilator-induced lung injury) may affect the magnitude of the respiratory variation in pleural pressure. It must be noted that most of these considerations remain theoretical, and studies are needed to clarify the influence of tidal volume and compliance of the respiratory system not only on the magnitude of arterial pressure variation but also on the hemodynamic response to a volume load.

**Effects of Anesthesia** The respiratory variation in stroke volume and arterial pressure has been validated as a predictor of fluid responsiveness only in mechanically ventilated and deeply sedated patients. This may limit the clinical usefulness of arterial pressure variation in

intensive care units, but not in the operating room, by far the largest field of application of this clinical tool. Predicting fluid responsiveness is useful in patients with acute circulatory failure in whom we believe that increasing cardiac output could be beneficial. Most patients with acute circulatory failure are sedated and mechanically ventilated. There is currently a trend toward using lower levels of sedation<sup>96</sup> or partial ventilatory support<sup>97</sup> (e.g., airway pressure release ventilation), but the correct assessment of respiratory mechanics (e.g., the measurement of airway plateau pressure or total PEEP) still requires respiratory and abdominal muscle relaxation, at least transiently.<sup>98</sup> In this regard, Morelot-Panzini *et al.*<sup>60</sup> recently proposed to combine the analysis of the arterial pressure waveform with the assessment of respiratory mechanics. This approach should extend the clinical usefulness of the respiratory variation in arterial pressure to most mechanically ventilated patients.

**Right Ventricular Failure** As mentioned above and illustrated in figure 3, one determinant of the respiratory variation in arterial pressure is the cyclic variation in right ventricular output impedance induced by the inspiratory increase in transpulmonary pressure. In acute cor pulmonale, this afterload effect may be a major determinant of the respiratory variation in pulmonary artery and hence aortic blood flows.<sup>40,99</sup> In this context, large swings in blood pressure have been reported in patients unresponsive to fluid administration.<sup>30,99</sup>

**Left Ventricular Failure** In the case of congestive heart failure, the main determinant of the respiratory variation in arterial pressure becomes the inspiratory increase in left ventricular stroke volume<sup>8</sup> (i.e., the  $\Delta$ up component of SPV). In this context, West zones III are predominant such that each mechanical breath increases pulmonary venous flow and left ventricular preload (fig. 4).<sup>41,42</sup> A failing ventricle is much more sensitive to changes in afterload than a normal ventricle.<sup>37</sup> The inspiratory reduction in left ventricular afterload has a more marked effect on left ventricular output than in the case of preserved contractility. However, it must be noted that the overall arterial pressure variation is not increased but reduced because the expiratory decrease in left ventricular stroke volume (i.e., the  $\Delta$ down component of SPV) becomes virtual.<sup>8</sup> In hypovolemic conditions, the vena cava and right atrium are poorly compliant and compressible and hence relatively insensitive to changes in pleural pressure. Because West zones III are predominant in the lungs, right ventricular afterload increases only very slightly during inspiration. Finally, because the Frank-Starling curve of a failing ventricle is flat<sup>37</sup> (fig. 5), any change in left ventricular preload induced by a mechanical breath is not able to produce a significant change in stroke volume. In summary, in congestive heart failure, a large respiratory variation in

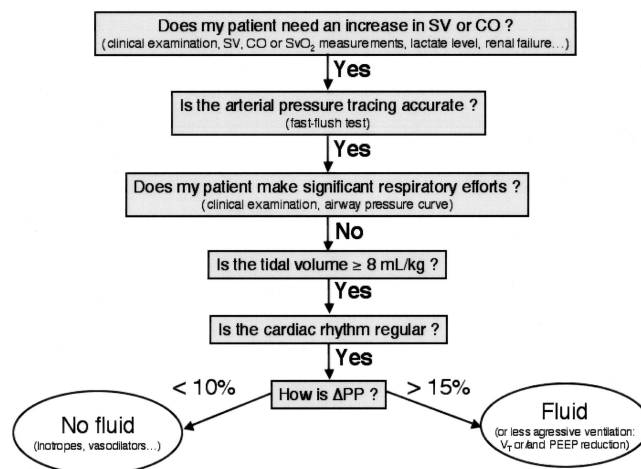

Fig. 9. How to assess the respiratory variation in arterial pressure in clinical practice. CO = cardiac output;  $\Delta$ PP = arterial pulse pressure variation; PEEP = positive end-expiratory pressure; SV = stroke volume;  $SvO_2$  = mixed venous oxygen saturation;  $V_T$  = tidal volume.

arterial pressure is unlikely. However, in hypovolemic patients with impaired left ventricular function, the respiratory variation in arterial pressure may be significant and, importantly, is still of value to predict fluid responsiveness. Reuter *et al.*<sup>27</sup> reported the same close relation between the magnitude of the pulse contour stroke volume variation and the increase in stroke volume as a result of fluid infusion in patients with reduced cardiac function (left ventricular ejection fraction < 35%) and in patients with preserved cardiac function (left ventricular ejection fraction > 50%).

## Conclusion

The respiratory variation in arterial pressure induced by mechanical ventilation, initially described as a “reversed pulsus paradoxus,”<sup>2</sup> has recently been revisited in several clinical studies demonstrating that this physical sign is neither an indicator of blood volume nor an accurate indicator of cardiac preload but a predictor of fluid responsiveness. These studies have demonstrated the value of this sign in answering one of the most common clinical questions, Can we use fluid to improve hemodynamics?, while static indicators of cardiac preload (cardiac filling pressures but also cardiac dimensions) are frequently unable to correctly answer this crucial question. The reliable analysis of the respiratory variation in arterial pressure is possible in most patients undergoing surgery and in critically ill patients who are sedated and mechanically ventilated with conventional<sup>100</sup> tidal volumes (fig. 9). Whether a goal-directed therapy taking into account the assessment of the respiratory variation in arterial pressure may improve the outcome of mechanically ventilated patients with shock remains an exciting but unsettled question.



The author thanks Jean-Louis Teboul, M.D., Ph.D. (Professor, Medical Intensive Care Unit, University Paris XI, Paris, France), Denis Chemla, M.D., Ph.D. (Professor, Department of Physiology, University Paris XI), and Azriel Perel, M.D. (Professor and Chairman, Anesthesia and Critical Care, Tel Aviv University, Tel Aviv, Israel), for insightful discussions about heart-lung interactions over the past few years; Luca M. Bigatello, M.D. (Associate Professor, Anesthesia and Critical Care, Harvard Medical School, Boston, Massachusetts), and Thomas Steffox, M.D., Ph.D. (Fellow, Anesthesia and Critical Care, Harvard Medical School), for their comments on the manuscript; Rae Allain, M.D. (Instructor, Anesthesia and Critical Care, Harvard Medical School), for English editing; and Maria De Amorim, R.N. (Medical Intensive Care Unit, University Paris XII), for her continuous support.

## References

- Bilchick KC, Wise RA: Paradoxical physical findings described by Kussmaul: Pulsus paradoxus and Kussmaul's sign. *Lancet* 2002; 359:1940-2
- Massumi RA, Mason DT, Vera Z, Zelis R, Otero J, Amsterdam EA: Reversed pulsus paradoxus. *N Engl J Med* 1973; 289:1272-5
- Vaisrub S: Paradoxical pulsus paradoxus (editorial). *JAMA* 1974; 229: 74
- Rick JJ, Burke SS: Respirator paradox. *South Med J* 1978; 71:1376-8
- Perel A, Pizov R, Cotev S: Systolic blood pressure variation is a sensitive indicator of hypovolemia in ventilated dogs subjected to graded hemorrhage. *ANESTHESIOLOGY* 1987; 67:498-502
- Michard F, Chemla D, Richard C, Wysocki M, Pinsky MR, Lecarpentier Y, Teboul JL: Clinical use of respiratory changes in arterial pulse pressure to monitor the hemodynamic effects of PEEP. *Am J Respir Crit Care Med* 1999; 159:935-9
- Pizov R, Ya'ari Y, Perel A: Systolic pressure variation is greater during hemorrhage than during sodium nitroprusside-induced hypotension in ventilated dogs. *Anesth Analg* 1988; 67:170-4
- Pizov R, Ya'ari Y, Perel A: The arterial pressure waveform during acute ventricular failure and synchronized external chest compression. *Anesth Analg* 1989; 68:150-6
- Szold A, Pizov R, Segal E, Perel A: The effect of tidal volume and intravascular volume state on systolic pressure variation in ventilated dogs. *Intensive Care Med* 1989; 15:368-71
- Preisman S, Pfeiffer U, Lieberman N, Perel A: New monitors of intravascular volume: a comparison of arterial pressure waveform analysis and the intrathoracic blood volume. *Intensive Care Med* 1997; 23:651-7
- Preisman S, DiSegni E, Vered Z, Perel A: Left ventricular preload and function during graded haemorrhage and retransfusion in pigs: analysis of arterial pressure waveform and correlation with echocardiography. *Br J Anaesth* 2002; 88:716-8
- Boldt J, Lenz M, Kumble B, Papsdorf M: Volume replacement strategies on intensive care units: Results from a postal survey. *Intensive Care Med* 1998; 24:147-51
- Connors Jr, AF Speroff T, Dawson NV, Thomas C, Harrel Jr, FE Wagner D, Desbiens N, Goldman L, Wu AW, Califf RM, Fulkerson Jr, WJ Vidaillet H, Broste S, Bellamy P, Lynn J, Knaus WA: The effectiveness of right heart catheterization in the initial care of critically ill patients. SUPPORT Investigators. *JAMA* 1996; 276:889-97
- Polanczyk CA, Rohde LE, Goldman L, Cook EF, Thomas EJ, Marcantonio ER, Mangione CM, Lee TH: Right heart catheterization and cardiac complications in patient undergoing noncardiac surgery: An observational study. *JAMA* 2001; 286:309-14
- Sandham JD, Hull RD, Brant RF, Knox L, Pineo GF, Doig CJ, Laporta DP, Viner S, Passerini L, Devitt H, Kirby A, Jacka M: Canadian Critical Care Clinical Trials Group: A randomized, controlled trial of the use of pulmonary artery catheters in high-risk surgical patients. *N Engl J Med* 2003; 348: 5-14
- Richard C, Warszawski J, Anguel N, Deye N, Combes A, Barnoud D, Boulain T, Lefort Y, Fartoukh M, Baud F, Boyer A, Brochard L, Teboul JL: Early use of the pulmonary artery catheter and outcomes in patients with shock and acute respiratory distress syndrome. *JAMA* 2003; 290:2713-20
- Michard F, Teboul JL: Predicting fluid responsiveness: A critical analysis of the evidence. *Chest* 2002; 121:2000-8
- Bendjelid K, Romand JA: Fluid responsiveness in mechanically ventilated patients: A review of indices used in intensive care. *Intensive Care Med* 2003; 29:352-60
- Kumar A, Anel R, Bunnell E, Habet K, Zanotti S, Marshall S, Neumann A, Ali A, Cheang M, Kavinsky C, Parrillo JE: Pulmonary artery occlusion pressure and central venous pressure fail to predict ventricular filling volume, cardiac performance, or the response to volume infusion in normal subjects. *Crit Care Med* 2004; 32:691-9
- Coriat P, Vrillon M, Perel A, Baron JF, Le Bret F, Saada M, Viars P: A comparison of systolic blood pressure variations and echocardiographic estimates of end-diastolic left ventricular size in patients after aortic surgery. *Anesth Analg* 1994; 78:46-53
- Tavernier B, Makhoutie O, Lebuffe G, Dupont J, Scherpereel P: Systolic pressure variation as a guide to fluid therapy in patients with sepsis-induced hypotension. *ANESTHESIOLOGY* 1998; 89:1313-21
- Michard F, Boussat S, Chemla D, Anguel N, Mercat A, Lecarpentier Y, Richard C, Pinsky MR, Teboul JL: Relation between respiratory changes in arterial pulse pressure and fluid responsiveness in septic patients with acute circulatory failure. *Am J Respir Crit Care Med* 2000; 162:134-8
- Feissel M, Michard F, Mangin I, Ruyet O, Faller JP, Teboul JL: Respiratory changes in aortic blood velocity as an indicator of fluid responsiveness in ventilated patients with septic shock. *Chest* 2001; 119:867-73
- Berkenstadt H, Margalit N, Hadani M, Friedman Z, Segal E, Villa Y, Perel A: Stroke volume variation as a predictor of fluid responsiveness in patients undergoing brain surgery. *Anesth Analg* 2001; 92:984-9
- Reuter DA, Kirchner A, Felbinger TW, Schmidt C, Lamm P, Goetz AE: Optimising fluid therapy in mechanically ventilated patients after cardiac surgery by on-line monitoring of left ventricular stroke volume variations: A comparison to aortic systolic pressure variations. *Br J Anesth* 2002; 88:124-6
- Reuter DA, Felbinger TW, Schmidt C, Kilger E, Goedje O, Lamm P, Goetz AE: Stroke volume variations for assessment of cardiac responsiveness to volume loading in mechanically ventilated patients after cardiac surgery. *Intensive Care Med* 2002; 28:392-8
- Reuter DA, Kirchner A, Felbinger TW, Weis FC, Kilger E, Lamm P, Goetz AE: Usefulness of left ventricular stroke volume variation to assess fluid responsiveness in patients with reduced cardiac function. *Crit Care Med* 2003; 31:1399-404
- Bendjelid K, Suter PM, Romand JA: The respiratory change in prejection period: A new method to predict fluid responsiveness. *J Appl Physiol* 2004; 96:337-42
- Marx G, Cope T, McCrossan L, Swaraj S, Cowan C, Mostafa SM, Wenstone R, Leuwer M: Assessing fluid responsiveness by stroke volume variation in mechanically ventilated patients with severe sepsis. *Eur J Anaesth* 2004; 21: 132-8
- Vieillard-Baron A, Chergui K, Rabiller A, Peyrouset O, Page B, Beauchet A, Jardin F: Superior vena caval collapsibility as a gauge of volume status in ventilated septic patients. *Intensive Care Med* 2004; 30:1734-9
- Morgan BC, Martin WE, Hornbein TF, Crawford EW, Guntheroth WG: Hemodynamic effects of intermittent positive pressure ventilation. *ANESTHESIOLOGY* 1966; 27:584-90
- Guyton A, Lindsey A, Abernathy B, Richardson T: Venous return at various right atrial pressures and the normal venous return curve. *Intensive Care Med* 1957; 189:609-15
- Pinsky MR: Determinants of pulmonary arterial flow variation during respiration. *J Appl Physiol* 1984; 56:1237-45
- Amoore JN, Santamore WP: Venous collapse and the respiratory variability in systemic venous return. *Cardiovasc Res* 1994; 28:472-9
- Vieillard-Baron A, Augarde R, Prin S, Page B, Beauchet A, Jardin F: Influence of superior vena caval zone conditions on cyclic changes in right ventricular outflow during respiratory support. *ANESTHESIOLOGY* 2001; 95: 1083-8
- Jardin F, Vieillard-Baron A: Right ventricular function and positive pressure ventilation in clinical practice: From hemodynamic subsets to respiratory settings. *Intensive Care Med* 2003; 29:1426-34
- Braunwald E, Sonnenblick EH, Ross J: Mechanisms of cardiac contraction and relaxation. *Heart Disease*. Edited by Braunwald E. Philadelphia, WB Saunders, 1988, pp 389-425
- Jardin F, Delorme G, Hardy A, Auvert B, Beauchet A, Bourdarias JP: Reevaluation of hemodynamic consequences of positive pressure ventilation: Emphasis on cyclic right ventricular afterloading by mechanical lung inflation. *ANESTHESIOLOGY* 1990; 72:966-70
- Poelaert JL, Visser CA, Everaert JA, De Deyne CS, Decruyenaere J, Colardyn FA: Doppler evaluation of right ventricular outflow impedance during positive-pressure ventilation. *J Cardiothorac Vasc Anesth* 1994; 8:392-7
- Vieillard-Baron A, Loubieres Y, Schmitt JM, Page B, Dubourg O, Jardin F: Cyclic changes in right ventricular output impedance during mechanical ventilation. *J Appl Physiol* 1999; 87:1644-50
- Brower R, Wise RA, Hassapoyannes C, Bromberger-Barnea B, Permutt S: Effect of lung inflation on lung blood volume and pulmonary venous flow. *J Appl Physiol* 1985; 58:954-63
- Vieillard-Baron A, Chergui K, Augarde R, Prin S, Page B, Beauchet A, Jardin F: Cyclic changes in arterial pulse during respiratory support revisited by Doppler echocardiography. *Am J Respir Crit Care Med* 2003; 168:671-6
- Pinsky MR, Matuschak GM, Klain M: Determinants of cardiac augmentation by elevations in intrathoracic pressure. *J Appl Physiol* 1985; 58:1189-98
- Abel JG, Salerno TA, Panos A, Greyson ND, Rice TW, Teoh K, Lichtenstein SV: Cardiovascular effects of positive pressure ventilation in humans. *Ann Thorac Surg* 1987; 43:198-206
- Fessler HE, Brower RG, Wise RA, Permutt S: Mechanism of reduced LV afterload by systolic and diastolic positive pleural pressure. *J Appl Physiol* 1988; 65:1244-50
- Jardin F, Farcot JC, Gueret P, Prost JF, Ozier Y, Bourdarias JP: Cyclic changes in arterial pulse during respiratory support. *Circulation* 1983; 68:266-74
- Chemla D, Hebert JL, Coirault C, Zamani K, Suard I, Colin P, Lecarpentier Y: Total arterial compliance estimated by stroke volume-to-aortic pulse pressure ratio in humans. *Am J Physiol* 1998; 274:H500-5
- Beaussier M, Coriat P, Perel A, Lebrete F, Kalfon P, Chemla D, Lienhart A, Viars P: Determinants of systolic pressure variation in patients ventilated after vascular surgery. *J Cardiothorac Vasc Anesth* 1995; 9:547-51
- Robotham JL, Cherry D, Mitzner W, Rabson JL, Lixfeld W, Bromberger-

- Barnea B: A re-evaluation of the hemodynamic consequences of intermittent positive pressure ventilation. *Crit Care Med* 1983; 11:783-93
50. Scharf SM, Brown R, Saunders N, Green LH: Hemodynamic effects of positive-pressure inflation. *J Appl Physiol* 1980; 49:124-31
  51. Denault AY, Gasior TA, Gorcsan III, J Mandarino WA, Deneault LG, Pinsky MR: Determinants of aortic pressure variation during positive pressure ventilation in man. *Chest* 1999; 116:176-86
  52. Feissel M, Michard F, Faller JP, Teboul JL: The respiratory variation in inferior vena cava diameter as a guide to fluid therapy. *Intensive Care Med* 2004; 30:1834-7
  53. Magder S, Georgiadis G, Cheong T: Respiratory variations in right atrial pressure predict the response to fluid challenge. *J Crit Care* 1992; 7:76-85
  54. Santamore WP, Amooore JN: Buffering of respiratory variations in venous return by right ventricle: A theoretical analysis. *Am J Physiol* 1994; 267:H2163-70
  55. West JB, Dollery CT, Naimark A: Distribution of blood flow in isolated lung: relation to vascular and alveolar pressure. *J Appl Physiol* 1964; 19:713-24
  56. Rooke GA, Schwid HA, Shapira Y: The effect of graded hemorrhage and intravascular volume replacement on systolic pressure variation in humans during mechanical and spontaneous ventilation. *Anesth Analg* 1995; 80:925-32
  57. Ornstein E, Eidelman LA, Drenger B, Elami A, Pizov R: Systolic pressure variation predicts the response to acute blood loss. *J Clin Anesth* 1998; 10:137-40
  58. Dalibon N, Schlumberger S, Saada M, Fischler M, Riou B: Haemodynamic assessment of hypovolaemia under general anaesthesia in pigs submitted to graded haemorrhage and retransfusion. *Br J Anaesth* 1999; 82:97-103
  59. Lai HY, Yang CCH, Huang FY, Lee Y, Kuo YL, Kuo TB: Respiratory-related arterial pressure variability as an indicator of graded blood loss: Involvement of the autonomic nervous system. *Clin Sci (Lond)* 2003; 105:491-7
  60. Morelot-Panzini C, Lefort Y, Derenne JP, Similowski T: Simplified method to measure respiratory-related changes in arterial pulse pressure in patients receiving mechanical ventilation. *Chest* 2003; 124:665-70
  61. Cohen MA, Taylor JA: Short-term cardiovascular oscillations in man: Measuring and modeling the physiologies. *J Physiol* 2002; 542:669-83
  62. Guz A, Innes JA, Murphy K: Respiratory modulation of left ventricular stroke volume in man measured using pulsed Doppler ultrasound. *J Physiol* 1987; 393:499-512
  63. Innes JA, De Cort SC, Kox W, Guz A: Within-breath modulation of left ventricular function during normal breathing and positive-pressure ventilation in man. *J Physiol* 1993; 460:487-502
  64. Slama M, Masson H, Teboul JL, Arnould ML, Susic D, Frohlich E, Andrejak M: Respiratory variations of aortic VTI: A new index of hypovolemia and fluid responsiveness. *Am J Physiol* 2002; 283:H1729-33
  65. Slama M, Masson H, Teboul JL, Arnould ML, Nait-Kaoudjt R, Colas B, Peltier M, Tribouilloy C, Susic D, Frohlich E, Andrejak M: Monitoring of respiratory variations of aortic blood velocity using esophageal Doppler. *Intensive Care Med* 2004; 30:1182-7
  66. Partridge BL: Use of pulse oximetry as a non-invasive indicator of intravascular volume status. *J Clin Monit* 1987; 3:263-8
  67. Shamir M, Eidelman LA, Floman Y, Kaplan L, Pizov R: Pulse oximetry plethysmographic waveform during changes in blood volume. *Br J Anaesth* 1999; 82:178-81
  68. Golparvar M, Naddafnia H, Saghaei M: Evaluating the relationship between arterial blood pressure changes and indices of pulse oximetric plethysmography. *Anesth Analg* 2002; 95:1686-90
  69. Shippy CR, Appel PL, Shoemaker WC: Reliability of clinical monitoring to assess blood volume in critically ill patients. *Crit Care Med* 1984; 12:107-12
  70. Marik PE: The systolic blood pressure variation as an indicator of pulmonary capillary wedge pressure in ventilated patients. *Anaesth Intensive Care* 1993; 21:405-8
  71. Xu H, Zhou S, Ma W, Yu B: Prediction of pulmonary arterial wedge pressure from arterial pressure or pulse oximetry plethysmographic waveform. *Chin Med J (Engl)* 2002; 115:1372-5
  72. Thys DM, Hillel Z, Goldman ME, Mindich BP, Kaplan JA: A comparison of hemodynamic indices derived by invasive monitoring and two-dimensional echocardiography. *ANESTHESIOLOGY* 1987; 67:630-4
  73. Cheung AT, Savino JS, Weiss SJ, Aukburg SJ, Berlin JA: Echocardiographic and hemodynamic indexes of left ventricular preload in patients with normal and abnormal ventricular function. *ANESTHESIOLOGY* 1994; 81:376-87
  74. Dalibon N, Guenoun T, Journois D, Frappier J, Safran D, Fischler M: The clinical relevance of systolic pressure variation in anesthetized nonhypotensive patients. *J Cardiothorac Vasc Anesth* 2003; 17:188-92
  75. Reuter DA, Goresch T, Goepfert MS, Wildhirt SM, Kilger E, Goetz AE: Effects of mid-line thoracotomy on the interaction between mechanical ventilation and cardiac filling during cardiac surgery. *Br J Anaesth* 2004; 92:808-3
  76. Michard F, Alaya S, Zarka V, Bahloul M, Richard C, Teboul JL: Global end-diastolic volume as an indicator of cardiac preload in patients with septic shock. *Chest* 2003; 124:1900-8
  77. Reuter DA, Bayerlein J, Goepfert MSG, Weis FC, Kilger E, Lamm P, Goetz A: Influence of tidal volume on left ventricular stroke volume variation measured by pulse contour analysis in mechanically ventilated patients. *Intensive Care Med* 2003; 29:476-80
  78. Tournadre JP, Allaouchiche B, Cayrel V, Mathon L, Chassard D: Estimation of cardiac preload changes by systolic pressure variation in pigs undergoing pneumoperitoneum. *Acta Anaesthesiol Scand* 2000; 44:231-5
  79. Pizov R, Cohen M, Weiss Y, Segal E, Cotev S, Perel A: Positive end-expiratory pressure-induced hemodynamic changes are reflected in the arterial pressure waveform. *Crit Care Med* 1996; 24:1381-7
  80. Perel A: Assessing fluid responsiveness by the systolic pressure variation in mechanically ventilated patients: Systolic pressure variation as a guide to fluid therapy in patients with sepsis-induced hypotension. *ANESTHESIOLOGY* 1998; 89:1309-10
  81. Pinsky MR: Functional hemodynamic monitoring. *Intensive Care Med* 2002; 28:386-388
  82. Michard F, Reuter DA: Assessing cardiac preload or fluid responsiveness: It depends on the question we want to answer (letter). *Intensive Care Med* 2003; 29:1396
  83. Michard F: Do we need to know cardiac preload? *Yearbook of Intensive Care and Emergency Medicine*. Edited by Vincent JL. Berlin, Springer Verlag, 2004, pp 694-701
  84. Harken AH, Brennan MF, Smith B, Barsamian EM: The hemodynamic response to positive end-expiratory ventilation in hypovolemic patients. *Surgery* 1974; 76:786-93
  85. Gardner RM: Direct blood pressure measurement: dynamic response requirements. *ANESTHESIOLOGY* 1981; 54:227-36
  86. Smulyan H, Safar ME: Systolic blood pressure revisited. *J Am Coll Cardiol* 1997; 29:1407-13
  87. Dorman T, Breslow MJ, Lipsett PA, Rosenberg JM, Balsler JR, Almog Y, Rosenfeld BA: Radial artery pressure monitoring underestimates central arterial pressure during vasopressor therapy in critically ill surgical patients. *Crit Care Med* 1998; 26:1646-9
  88. Stern DH, Gerson JI, Allen FB, Parker FB: Can we trust the direct radial artery pressure immediately following cardiopulmonary bypass? *ANESTHESIOLOGY* 1985; 62:557-61
  89. Lai HY, Yang CC, Cheng CF, Huang FY, Lee Y, Shyr MH, Kuo TB: Effect of esmolol on positive-pressure ventilation-induced variations of arterial pressure in anesthetized humans. *Clin Sci (Lond)* 2004; 107:303-8
  90. Korach M, Sharshar T, Jarrin I, Fouillot JP, Raphael JC, Gajdos P, Annane D: Cardiac variability in critically ill adults: influence of sepsis. *Crit Care Med* 2001; 29:1380-5
  91. The Acute respiratory Distress Syndrome Network: Ventilation with lower tidal volumes as compared with traditional tidal volumes for acute lung injury and the acute respiratory distress syndrome. *N Engl J Med* 2000; 342:1301-8
  92. Michard F, Teboul JL, Richard C: Influence of tidal volume on stroke volume variation: Does it really matter? (letter). *Intensive Care Med* 2003; 29:1613
  93. Magder S: Clinical usefulness of respiratory variations in arterial pressure. *Am J Respir Crit Care Med* 2004; 169:151-5
  94. Jardin F, Genevray B, Brun-Ney D, Bourdarias JP: Influence of lung and chest wall compliances on transmission of airway pressure to the pleural space in critically ill patients. *Chest* 1985; 88:653-8
  95. Teboul JL, Pinsky MR, Mercat A, Anguel N, Bernardin G, Achard JM, Boulain T, Richard C: Estimating cardiac filling pressure in mechanically ventilated patients with hyperinflation. *Crit Care Med* 2000; 28:3631-6
  96. Kress JP, Pohlman AS, O'Connor MF, Hall JB: Daily interruption of sedative infusions in critically ill patients undergoing mechanical ventilation. *N Engl J Med* 2000; 342:1471-7
  97. Putensen C, Zech S, Wrigge H, Zinserling J, Stuber F, Von Spiegel T, Mutz N: Long-term effects of spontaneous breathing during ventilatory support in patients with acute lung injury. *Am J Respir Crit Care Med* 2001; 164:43-9
  98. Tobin MJ: Respiratory monitoring. *JAMA* 1990; 264:244-51
  99. Jardin F: Cyclic changes in arterial pressure during mechanical ventilation. *Intensive Care Med* 2004; 30:1047-50
  100. Eichacker PQ, Gerstenberger EP, Banks SM, Cui X, Natanson C: Meta-analysis of acute lung injury and acute respiratory distress syndrome trials testing low tidal volumes. *Am J Respir Crit Care Med* 2002; 166:1510-4